



SPECIFICATIONS

9124

INDUSTRIAL FANS

24" Pedestal Fan

- **Motor**
3-speed, 1/4 HP, 120V, 1 phase, totally enclosed, ball bearing, permanently lubricated, permanent split capacitor
- **Controls**
Rear mounted rotary switch
- **Power Cord**
Black, 10', 3-conductor, S type
- **Coating**
Blade, Guard, and Mounts are powder coated steel
- **Compliance**
ETL, OSHA
- **Height**
Adjustable from 53" to 76.5"
- **Shipping Information**
UPC: 0-46013-39500-9
Shipping Weight: 73.5 lbs.
- **Product Dimensions**
27"L x 29"W x 76.5"H

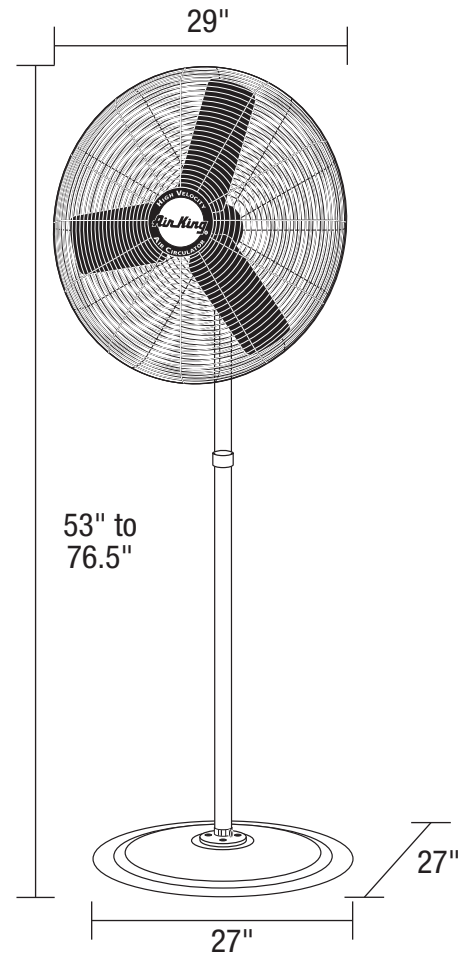

MODEL	CFM			RPM			AMPS			WATTS			DB A		
	HIGH	MED	LOW	HIGH	MED	LOW	HIGH	MED	LOW	HIGH	MED	LOW	HIGH	MED	LOW
9124	5130	4490	3670	1060	925	745	2.4	1.9	1.5	252	199	157	72	69	64



U.S.: 820 Lincoln Drive
West Chester, Pennsylvania 19380-4466
Tel: (610) 692-7400 • 877-304-3785
Fax: (610) 696-8048